

The Influence of Work Environment and Discipline on Performance Through Additional Employee Income (TPP) at the Regional Secretariat of Kendal Regency.

Novita Dwi Anggraheni¹, Bambang Guritno², Aurilia Triani Aryaningtyas³

¹⁻³ Sekolah Tinggi Ilmu Ekonomi Pariwisata Indonesia, Semarang, Indonesia

Corresponding email: bguritno18@gmail.com

Abstract. This research was conducted at the Regional Secretariat of Kendal Regency, which aims to analyze and explain the effect of the work environment and discipline on additional employee income (TPP), analyze and explain the effect of the work environment, discipline and additional employee income (TPP) on performance and analyze and explain the influence of the work environment and discipline on performance through additional employee income (TPP). This study used a sample of 137 people. The data collection method uses observation, questionnaires and documentation. Instrument feasibility test using validity test and reliability test. For tehnik data analysis using multiple regression analysis and model test. The results of this study state that the work environment and discipline affect the additional employee income (TPP), work environment, discipline and additional employee income (TPP) affect performance, and additional employee income (TPP) does not mediate the effect of work environment and discipline on performance

Keywords : Work Environment; Discipline; Additional Employee Income (TPP); Performance.

INTRODUCTION

In carrying out its duties, the Regional Secretariat of Kendal Regency has the following functions: (1) coordinating the preparation of regional policies; (2) coordinating the implementation of Regional Apparatus tasks; (3) monitoring and evaluating the implementation of Regional policies; (4) administrative services and development of state civil servants in regional agencies; and (5) carrying out other tasks assigned by the Regent related to his duties and functions. Therefore, to carry out this function, maximum employee performance is needed so that it is in line with their expectations and responsibilities.

From the results of the researcher's observations at the Kendal Regency Regional Secretariat through the results of the researcher's interviews with 10 employees regarding performance can be seen in the table below:

Performance of 10 Employees

Employee performance variable indicators	Statement	Answer	
		Agree	Don't agree
Quantity aspect	Employees complete work according to management's expectations	8	2
Quality aspect	Employees complete additional tasks outside of their workload	6	4
Time aspect	Employees complete tasks on time according to established regulations	7	3
Cost aspect	Employees submit the results of the analysis of cost requirements on time	9	1
Service orientation	Employees provide service orientation to the	10	-

Received November 19, 2023; Revised Desember 01, 2023; Accepted Desember 31, 2023

* Novita Dwi Anggraheni , bguritno18@gmail.com

	community		
Integrity	Complete work obediently and comply with systems and procedures	10	-
Commitment	Employees work according to SOP in completing work	8	2
Discipline	Employees leave and return according to working hours	4	6
Cooperation	Employees are obliged to coordinate tasks with other parties, including other organizations	10	-
Leadership	Leaders motivate employees and communicate well	8	2

Source; 2023 primary data

Based on the information in the table above, it can be concluded that the performance of the Kendal Regency Regional Secretariat employees is not optimal because there are still feelings of disagreement among employees, mostly on the point of discipline. This happens because many employees are late coming to work. Therefore, it is important to pay attention to this aspect of discipline so that it is more optimal so that in the end it does not affect the decline in employee performance. The research results of (Suprihati, 2014) stated that each variable of training, motivation, incentives and work environment had a significant effect on employee performance.

Based on the results of observations by researchers at the Kendal Regency Regional Secretariat, the work environment problem that is the main complaint of employees is that unhealthy competition occurs between fellow employees by bringing down other employees, so this tends to affect the comfort of the employee's work environment. The problem of lack of cooperation between employees also often occurs which has an impact on reducing employee performance. Therefore, this problem needs to get the attention of employees so that it does not happen again so that the comfortable working environment has an influence on improving employee performance.

Based on the results of observations by researchers at the Regional Secretariat of Kendal Regency, the disciplinary problems that occur are that the behavior of some employees tends to be selfish, especially in work meetings, they do not want to accept opinions in the form of input and criticism from other employees, resulting in poor employee work ethics. Then the next problem is employee discipline regarding work standards that are not paid enough attention to, such as being late in completing work, employees whose attendance or absenteeism is not optimal and not attending morning roll call, afternoon roll call, late fingerprint and not filling in daily work reports where each employee is required to complete each main task. working days and these reports are outlined in the LapHar application, ultimately resulting in a decline in employee performance. Therefore, this

problem needs to be paid more attention by the management of the regional secretariat so that they reprimand their employees who are negligent in paying attention to discipline.

Based on the results of researchers' observations at the Kendal Regency Regional Secretariat, the problem with additional employee income (TPP) that employees complained about was that there were additional cuts to employee income at the Kendal Regency Regional Secretariat which resulted in reduced employee dissatisfaction, resulting in a decrease in employee performance. Therefore, this problem should be brought to the attention of the Kendal district government so that it can satisfy employees and thus improve their performance.

Formulation of the problem

1. How does the work environment influence employee additional income (TPP) at the Kendal Regency Regional Secretariat?
2. How does employee discipline influence employee additional income (TPP) at the Kendal Regency Regional Secretariat?
3. How does the work environment influence employee performance at the Kendal Regency Regional Secretariat?
4. How does employee discipline influence employee performance at the Kendal Regency Regional Secretariat?
5. How does additional employee income (TPP) affect employee performance at the Kendal Regency Regional Secretariat?
6. How does the work environment influence employee performance through additional employee income (TPP) at the Kendal Regency Regional Secretariat?
7. How does employee discipline affect employee performance through additional employee income (TPP) at the Kendal Regency Regional Secretariat?

METHOD

Types of research

This research uses a quantitative approach, namely research that is used to examine certain populations and samples and uses data collection with research instruments that aim to test predetermined hypotheses.

Research design

Research design is a framework or plan for conducting research. The design used in this research is as follows:

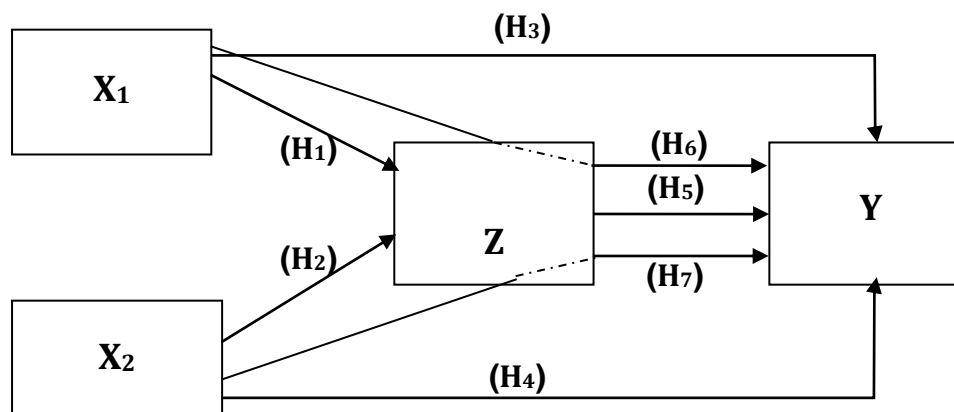

Research design

Information:

- X1: Work Environment
- X2: Discipline
- Z: Additional Employee Income (TPP)
- Y: Performance

The research object is Civil Servants (PNS) who work at the Kendal Regency Regional Secretariat. The time for carrying out this research starts from the initial survey, preparation of proposals, implementation and processing of data and reporting for five months starting from June 2023 to October 2023.

Research Population

According to (Sugiyono, 2013) Population is a generalized area consisting of objects/subjects that have certain qualities and characteristics determined by researchers to be studied and then conclusions drawn. According to (Alma, 2015) Population is the totality of characteristics or units of measurement results that are the object of research. Looking at the opinion above, it can be concluded that a population is an object or subject that resides in an area and meets certain requirements related to the research problem. In connection with the research to be conducted, the population in this study is all employees who work at the Kendal Regency Regional Secretariat, totaling 138 employees. The following is the number of employees at the Kendal Regency Regional Secretariat:

Number of Kendal Regency Regional Secretariat Employees

No.	List of Respondents	Number of Employees (People)
1.	regional Secretary	1
2.	Regent's Expert Staff	3
3.	Assistant	3
4.	General Affair	38
5.	Leadership Protocol and Communication Section	12
6.	Organization Section	10

7.	Law part	10
8.	People's Welfare Section	10
9.	Government Section	8
10.	Development Administration Section	7
11.	Goods and Services Procurement Department	25
12.	Economic Section	11
	TOTAL NUMBER	138

Source: Kendal Regency Regional Secretariat, 2023

Research Sample

According to (Riduwan, 2015), a sample is a part of the population that has certain characteristics or conditions that will be studied. The sampling technique used in this research used the census sampling technique. According to (Sugiyono, 2013) census sampling is a sampling technique if all members of the population are used as samples, which is the entire population, namely 137 employees (1 as researcher)

Method of collecting data

Observation

According to (Arikunto, 2012). Observation is an observation, including the activity of paying attention to an object using all the sense organs which include sight, smell, hearing, touch, taste. Observations in this research were used to obtain data about the influence of the work environment and discipline on performance through additional employee income (TPP) at the Kendal Regency Regional Secretariat

Questionnaire

Researchers created a questionnaire for this research to obtain data related to Work Environment (Variable X1), Discipline (Variable X2), Additional Employee Income (TPP) (Variable Z) and Performance (Variable Y). The researcher gave the questionnaire to employees at the Kendal Regency Regional Secretariat. In order to simplify the process of making the questionnaire, the researcher first made a research instrument grid.

The questionnaire is equipped with a measurement scale to produce quantitative data. The Likert scale was used in this research to measure the attitudes, opinions and perceptions of employees at the Kendal Regency Regional Secretariat regarding these variables. There are 5 (five) answer choices for each question item, namely:

1. Answer Strongly Agree (SS): given a score of 5
2. Answer Agree (S): given a score of 4
3. Answer Simply Agree (CS): given a score of 3
4. Answer Disagree (TS): given a score of 2
5. Answer Strongly Disagree (STS): given a score of 1

Meanwhile, performance measurement will use the regulations contained in the Minister for Administrative Reform and Bureaucratic Reform Number 3 of 2021, with the following value conversion:

Civil Servant Performance Criteria according to Civil Servant Performance Based on the Minister for Administrative Reform and Bureaucratic Reform Number 3 of 2021

Assessment	Value	Likert Scale Conversion
Very good	If civil servants have a score of 110 – 120. Create new ideas and/or new ways to improve performance that provide benefits to the organization or country;	5
Good	If a civil servant has a score of 90 – 120	4
Enough	If a civil servant has a score of 70 (seventy) <- 89 (ninety)	3
Not enough	If civil servants have a value of 50 (fifty) – 69 (seventy); And	2
Very less	If a civil servant has a score < 50 (fifty).	1

Source: Kendal Regional Secretariat Primary Data, 2023

Next, the data obtained from the respondents' answers is collected and entered into a table as primary data (tabulating). The primary data collected was processed using the SPSS for Windows Ver 25.0 statistical program Data analysis technique

Multiple Regression Analysis

Regression analysis is used to see the influence of the independent variable on the dependent variable. In this research, regression analysis was carried out using direct regression to determine the influence of the work environment and discipline on performance through additional employee income (TPP) at the Kendal Regency Regional Secretariat.

Mathematical Model:

$$Z = \beta_1 X_1 + \beta_2 X_2$$

$$Y = \beta_3 X_1 + \beta_4 X_2 + \beta_5 Z$$

Where :

X1: Work Environment

X2: Discipline

Z: Additional Employee Income (TPP)

Y: Performance

β_1 -5: Regression Coefficient

Model Test

a. Determination Coefficient Test (R² Test)

The coefficient of determination (R Square) is used to find out how much percentage can be explained by 1) work environment and discipline on additional employee

income (TPP) and 2) work environment, discipline and additional employee income (TPP) on employee performance

b. F test

The model test / anova is to see how all the independent variables together influence the dependent variable. Or to test whether the regression model we created is good/significant or not good/non-significant. The F test is carried out by comparing the calculated F with the F table. If $F_{\text{count}} > F_{\text{table}}$ then H_a is accepted. With a significance level = 0.05%. The F test here is to explain the joint influence of 1) work environment and discipline on additional employee income (TPP) and 2) work environment, discipline and additional employee income (TPP) on employee performance

c. t Test (Partial)

The t test basically shows how much influence an independent variable individually has in explaining variations in the dependent variable. Testing via the t test is carried out by comparing the calculated t with the t table at $\alpha = 5\%$ (0.05).

d. Mediation Test

Testing the mediation effect in this research was by comparing direct and indirect effects. Direct influence occurs if one variable influences another without a third variable mediating the two variables. Indirect influence is if there is a third variable that mediates the relationship between the two variables. In this research, to test the influence of mediating variables using the path analysis method with the following steps:

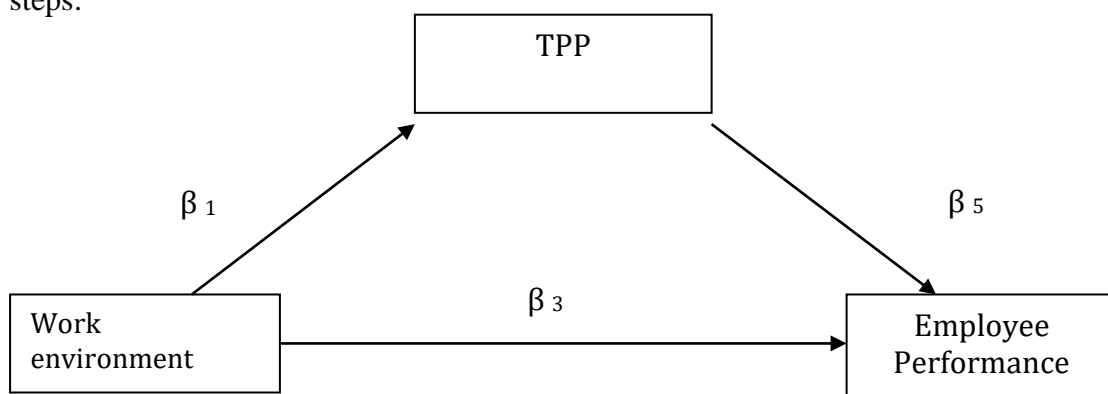

Testing the mediation of the Work Environment on Performance through Additional Employee Income (TPP).

The mediation requirement is that the TPP variable mediates the work environment variable on the performance variable if $(\beta_1 \times \beta_5) > \beta_3$

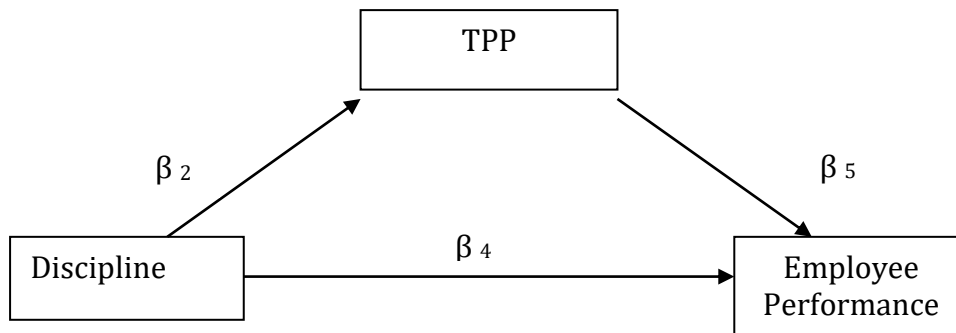

Testing the mediation of Discipline on Performance through Additional Employee Income (TPP).

Mediation conditions: TPP variables mediate discipline variables on employee performance variables if $(\beta 2 \times \beta 5) > \beta 4$.

RESULTS AND DISCUSSION

The Influence of the Work Environment on Additional Employee Income (TPP)

Based on the results of research and data processing, the significance value of the work environment variable is $0.008 < 0.05$, so the conclusion is that the first hypothesis is accepted, namely that the work environment variable has a positive and significant influence on additional employee income.

The dimension that has the highest mean score is the relationship between co-workers dimension of 4.06. This result is the result of the answers given by respondents with the majority agreeing and feeling that it is true that colleagues in the office are happy in the statement, in the office there is an attitude of reminding each other between colleagues and colleagues in the office providing support and assistance to each other because it has always been felt This is because the relationship that exists between all good employees who both support each other in every activity in their work environment which ultimately greatly influences the increase in additional employee income (TPP).

The dimension that has the lowest mean score is the dimension of the relationship between subordinates and leaders at 3.97. This result is the result of the answers given by respondents with the majority agreeing and feeling that the superiors always respect the opinions of subordinates, superiors are very good at determining strategies and superiors can cooperate with them because even though all the attitudes and behavior of superiors towards subordinates are not significant has an influence on additional employee income (TPP) whose amount and nominal has been determined

From the explanation of each of these dimensions, it can be concluded that the work environment can influence the increase in employee additional income (TPP). According to (Nitisemito, 2014) the work environment is everything that is around the worker and that can influence him in carrying out the assigned tasks. A safe, comfortable and positive work environment can have a good influence on providing additional employee income (TPP).

The conclusion that can be conveyed from the research results described above is that the work environment has an influence on additional employee income (TPP).

The Effect of Discipline on Additional Employee Income (TPP)

Based on the results of research and data processing, the significance value of the discipline variable is $0.011 < 0.05$, so the conclusion is that the second hypothesis is accepted, namely that the discipline variable positively and significantly has an influence on additional employee income (TPP).

The dimension that has the highest mean score is the work ethics dimension of 4.08. This result is the result of answers given by respondents with the majority agreeing and feeling true to the statement that employees have a good personality at work and employees have good behavior at work because the employee's good personality at work and behavior can serve as a guideline for employee discipline. well, this ultimately greatly influences the increase in additional employee income (TPP)

The dimension that has the lowest mean score is the dimension of compliance with work standards of 3.92. This result is the result of answers given by respondents with the majority agreeing and feeling that it is true in the statement that employees work carefully so that there are no errors in the employee's work and employees use equipment provided by the office and return it when finished because they work carefully and use the equipment provided. The office does not have a significant influence on additional employee income (TPP), the amount and nominal of which has been determined

From the explanation of each of these dimensions, it can be concluded that discipline can influence the increase in additional employee income (TPP). According to (Sutrisno, 2009) discipline is a tool that managers use to communicate with employees so that they are willing to change behavior and as an effort to increase a person's awareness and willingness to comply with all company regulations and applicable social norms.

The conclusion that can be conveyed from the research results described above is that discipline has an influence on additional employee income (TPP).

The Influence of the Work Environment on Employee Performance

Based on the results of research and data processing, the significance value of work

environment variables is $0.040 < 0.05$, so the conclusion is that the third hypothesis is accepted, namely that work environment variables positively and significantly influence employee performance.

The dimension that has the highest mean score is the relationship between co-workers dimension of 4.06. This result is the result of the answers given by respondents with the majority agreeing and feeling that it is true that colleagues in the office are happy with the statement, in the office there is an attitude of reminding each other between colleagues and colleagues in the office providing support and assistance to each other because it has always been felt This is because the relationship that exists between all good employees who both support each other in every activity in their work environment which ultimately greatly influences the improvement of employee performance.

The dimension that has the lowest mean score is the dimension of the relationship between subordinates and leaders at 3.97. This result is the result of the answers given by respondents with the majority agreeing and feeling that the superiors always respect the opinions of subordinates, superiors are very good at determining strategies and superiors can cooperate with them because even though all the attitudes and behavior of superiors towards subordinates are not significant has an influence on employee performance

From the explanation of each of these dimensions, it can be concluded that the work environment can influence employee performance improvement. According to Nitisemito (2014) the work environment is everything that is around the worker and that can influence him in carrying out the assigned tasks. A safe, comfortable and positive work environment can have a good influence on improving employee performance, which is then supported by (Rodhiyah & Widyasari, 2022) with the results of compensation (X1) and work environment (X2) having an influence on the performance variable (Y).

The conclusion that can be conveyed from the research results described above is that the work environment has an influence on employee performance

The Influence of Discipline on Employee Performance

Based on the results of research and data processing, the significance value of the discipline variable is $0.041 < 0.05$, so the conclusion is that the fourth hypothesis is accepted, namely that the discipline variable positively and significantly influences employee performance.

The dimension that has the highest mean score is the work ethics dimension of 4.08. This result is the result of answers given by respondents with the majority agreeing and feeling true to the statement that employees have a good personality at work and employees

have good behavior at work because the employee's good personality at work and behavior can serve as a guideline for employee discipline. Well, ultimately this greatly influences the improvement of employee performance. The dimension that has the next highest mean score is the dimension of compliance with work regulations at 4.02. This result is the result of answers given by respondents with the majority agreeing and feeling that the employee really understands the existing work regulations and that employees always try to carry out their duties well and according to existing rules because the attitude of employees who try to carry out their duties well and according to the rules. Existing rules can serve as a guideline to ensure employee discipline is good, which ultimately greatly influences employee performance improvement

The dimension that has the lowest mean score is the dimension of compliance with work standards of 3.92. This result is the result of answers given by respondents with the majority agreeing and feeling that it is true in the statement that employees work carefully so that there are no mistakes in the employee's work and employees use equipment provided by the office and return it when finished because they work carefully and use the equipment provided. The office has no significant influence on employee performance

From the explanation of each of these dimensions, it can be concluded that discipline can influence increased employee performance. According to (Sutrisno, 2009) discipline is a tool used by managers to communicate with employees so that they are willing to change behavior and as an effort to increase a person's awareness and willingness to obey all company regulations and applicable social norms, then supported by Budi's research. (Saputro et al., 2018) with the results that work discipline, work compensation, and work environment have a significant effect together (simultaneously) on employee performance at the Ciputat District Office, South Tangerang, partially.

The conclusion that can be conveyed from the research results described above is that discipline has an influence on employee performance

The Effect of Additional Employee Income (TPP) on Employee Performance

Based on the results of research and data processing, the significance value of the additional variable employee income (TPP) is $0.001 < 0.05$, so the conclusion is that the fifth hypothesis is accepted, namely the additional variable employee income (TPP) positively and significantly influences employee performance.

The dimension that has the highest mean score is the position allowance dimension of 4. This result is the result of answers given by respondents with the majority agreeing and feeling that it is true in the statement that employees receive allowances based on their

workload and employees receive allowances according to the value of the services they provide because Receiving allowances based on workload and according to service can be a guideline that providing additional employee income (TPP) is good, which in turn greatly influences employee performance improvement.

The dimension that has a low mean score is the performance allowance dimension of 3.97. This result is the result of answers given by respondents with the majority agreeing and feeling that it is true in the statement that employees receive allowances from the results of their work achievements and employees receive allowances in accordance with their SAKIP score because receiving allowances from their work achievements and SAKIP scores does not have a significant influence on employee performance

From the explanation of each of these dimensions, it can be concluded that additional employee income (TPP) can influence increased employee performance. According to the Decree of the Mayor of Semarang Number 800/1284 of 2018 concerning the amount and assessment of additional employee income for civil servants within the Semarang City Government for Budget Year 15 2019. TPP is additional employee income given to civil servants and CPNS which is based on employee performance achievements, then supported by research by (Sari et al., 2022) with the results that providing additional employee income (TPP) has a positive and significant effect on employee performance at the Jenepono Regency Education and Culture Office.

The conclusion that can be conveyed from the research results described above is that additional employee income (TPP) has an influence on employee performance

The Influence of the Work Environment on Employee Performance through Additional Employee Income (TPP)

Based on the results of research and data processing, the calculated values for the mediation test produce:

$$(0.234 \times 0.325) > 0.044 = \text{meaning the value of } \beta_1 \times \beta_5 > \beta_3$$

$$(0.076) > 0.044 = \text{meaning the value of } \beta_1 \times \beta_5 > \beta_3$$

Based on the above, the conclusion is that the additional variable employee income (TPP) mediates the influence of the work environment on employee performance because the value of $\beta_1 \times \beta_5 < \beta_3$ ($0.076 < 0.044$). So the conclusion is that the sixth hypothesis is accepted, namely that the additional variable employee income (TPP) positively and significantly mediates the influence of the work environment on employee performance.

From the results of the researcher's observations in the field, it is true that the dimensions of relationships between co-workers in the work environment variable have been

carried out well because all employees maintain their relationships with each other, such as: junior employees respect senior employees, the working environment is pleasant because there is always joy that is expressed, there is an attitude between employees who remind each other of their obligations to complete the work and provide mutual motivational support have been carried out, which in the end from this example becomes important evidence that if relationships between co-workers are carried out well, their performance will increase, but increasing employee performance can also increase additional employee income. (TPP) because the policy of providing additional employee income (TPP) has been determined by the government, if the work environment is conducive, then additional employee income (TPP) will increase

The conclusion that can be conveyed from the research results described above is that additional employee income (TPP) mediates the influence of the work environment on employee performance.

The Effect of Discipline on Employee Performance through Additional Employee Income (TPP)

Based on the results of research and data processing, the calculated values for the mediation test produce:

$$(0.144 \times 0.325) < 0.272 = \text{meaning the value of } \beta_2 \times \beta_5 < \beta_4$$

$$(0.046) < 0.272 = \text{meaning the value of } \beta_2 \times \beta_5 < \beta_4$$

Based on the above, the conclusion is that the additional variable employee income (TPP) mediates the effect of discipline on employee performance because the value of $\beta_2 \times \beta_5 < \beta_4$ ($0.046 < 0.272$). So the conclusion is that the seventh hypothesis is rejected, namely that the additional variable employee income (TPP) does not positively and significantly mediate the effect of discipline on employee performance.

From the results of observations by researchers in the field, it is true that the dimensions of work ethics have been carried out well because most of the employees have good personalities when it comes to work, for example: employees smile and are enthusiastic when carrying out work activities in the office. The excellent behavior of employees is also proven by employee compliance regarding absences and attendance at the office, employee obedience to leadership orders and employee obedience in upholding honest behavior by not committing acts of corruption. This is an important point that employee work ethics are put forward so that the consequences of this can affect increasing employee performance, however increasing employee performance does not necessarily increase employee additional income (TPP) because the policy of providing additional employee income (TPP) has been

determined by the government, if the work environment is conducive, then additional employee income (TPP) will not increase

The conclusion that can be conveyed from the research results described above is that additional employee income (TPP) does not mediate the effect of discipline on employee performance.

CONCLUSION

Based on the results of the research and discussion, the conclusions that emerge from this research are as follows:

1. The work environment has a positive and significant effect on additional employee income (TPP) at the Kendal Regency Regional Secretariat.
2. Discipline has a positive and significant effect on additional employee income (TPP) at the Kendal Regency Regional Secretariat
3. The work environment has a positive and significant effect on employee performance at the Kendal Regency Regional Secretariat
4. Discipline has a positive and significant effect on employee performance at the Kendal Regency Regional Secretariat
5. Additional employee income (TPP) has a positive and significant effect on employee performance at the Kendal Regency Regional Secretariat
6. Additional employee income (TPP) positively and significantly mediates the influence of the work environment on employee performance at the Kendal Regency Regional Secretariat
7. Positive and significant additional employee income (TPP) does not mediate the influence of discipline on employee performance at the Kendal Regency Regional Secretariat

REFERENCES

- Alma, B. (2015). *Marketing Management and Services Marketing*.
- Arikunto, S. (2012). *Research Procedures A Practice Approach*.
- Nitisemito, A. S. (2014). *Personnel Management*.
- Riduwan. (2015). *Basics of Statistics*.
- Rodhiyah, I., & Widayari, P. (2022). Self-Compassion and Hope in Inclusive School Teachers. *Psychopathic: A Scientific Journal of Psychology*, 8(2), 261–270. <https://doi.org/10.15575/psy.v8i2.6373>
- Saputro, A., Sugiharto, D. S., Studi, P., Marketing, M., Economy, F., Petra, U. K., & Siwalankerto, J. (2018). Brand Ambassador Dimensions. *Marketing Strategy*, 5, 1–8.

Sari, N. F., Sijabat, R., & Indiworo, H. E. (2022). The Influence of E-Kinerja, Work Discipline, and TPP on ASN Performance at the Rembang Regency Dindagkop UKM. *Journal of Finance and Business Digital*, 1(1), 55–70. <https://doi.org/10.55927/jfbd.v1i1.1221>

Sugiyono. (2013). *Quantitative Qualitative Research Methods and R&D*.

Suprihati. (2014). Analysis of Factors That Influence the Performance of Sari Jati Company Employees in Sragen. *Paradigm Journal*, Vol. 12, no. 1, ISSN 1693-0827.

Sutrisno. (2009). *Human Resource Management*.